

**Part Number: PTR07-18130**

**Kit Contents**

Item #	Quantity Req.	Description
1	2	Coil, Front
2	2	Coil, Rear
3	1	Hardware Kit
4	1	Installation Instructions

**Hardware Bag Contents**

Item #	Quantity Req.	Description
1	2	Spring Bumper, Front
2	2	Spring Bumper, Rear
3	2	M12 self-lock nut
4	4	M12 self-lock nut
5	6	M10 self-lock nut
6	6	M8 spacer skirt nut
7	2	M12 flange nut
8	4	M14 flange nut

**Additional Items Required For Installation**

Item #	Quantity Req.	Description

**Conflicts**

Fog Lamps (California only)
-----------------------------

**Recommended Tools**

<b>Personal &amp; Vehicle Protection</b>	<b>Notes</b>
<b>Special Tools</b>	<b>Notes</b>
SST: 09729-97202	For Front Strut Upper Nut
SST: 09729-18010	For Rear Damper Upper Nut
Spring Compressor	For Front & Rear Spring
<b>Installation Tools</b>	<b>Notes</b>
Screwdriver	Flat Blade
Ratchet	3/8" & 1/2"
Sockets	12, 14, 17, 19, 22mm
Spark Plug Sockets	14, 17mm
Crowfoot Wrenches	17, 19mm
Wrenches	14, 17, 19, 22mm
Ratchet Wrenches	17, 19mm
Hex Wrench	5, 6mm
Torque Wrench	
<b>Special Chemicals</b>	<b>Notes</b>

**General Applicability**

All Models
------------

**Recommended Sequence of Application**







Item #	Accessory
1	TRD Lowering Springs
2	TRD Sway Bar Kit
3	

\*Mandatory

**Vehicle Service Parts** (may be required for reassembly)

Item #	Quantity Req.	Description
1		
2		
3		

**Legend**

	<b>STOP:</b> Damage to the vehicle may occur. Do not proceed until process has been complied with.
	<b>OPERATOR SAFETY:</b> Use caution to avoid risk of injury.
	<b>CAUTION:</b> A process that must be carefully observed in order to reduce the risk of damage to the accessory/vehicle and to ensure a quality installation.
	<b>TOOLS &amp; EQUIPMENT:</b> Used in Figures calls out the specific tools and equipment recommended for this process.
	<b>REVISION MARK:</b> This mark highlights a change in installation with respect to previous issue.
	<b>SAFETY TORQUE:</b> This mark indicates that torque is related to safety.

Care must be taken when installing this accessory to ensure damage does not occur to the vehicle. The installation of this accessory should follow approved guidelines to ensure a quality installation.

These guidelines can be found in the "Accessory Installation Practices" document.

This document covers such items as:-

- Vehicle Protection (use of covers and blankets, cleaning chemicals, etc.).
- Safety (eye protection, rechecking torque procedure, etc.).
- Vehicle Disassembly/Reassembly (panel removal, part storage, etc.).
- Electrical Component Disassembly/Reassembly (battery disconnection, connector removal, etc.).

Please see your Toyota dealer for a copy of this document.

**HINT:**

- The procedures listed below are for the LH side.
- Use the same procedure for the RH side and LH side.

**1. Remove the Front Shock Absorber and Spring Assembly.**

- (a) Remove the front suspension support dust covers and retain them for installation (Fig. 1-1).

**HINT:** Loosening the spring assembly lock nut while the vehicle is on the ground will help with the removal process during disassembly. **DO NOT COMPLETELY REMOVE IT.**

- (b) Remove the front wheels.

- (c) Use a flat blade screwdriver to remove the two clamps and separate the front speed sensor from the front shock absorber with coil spring (Fig. 1-2).

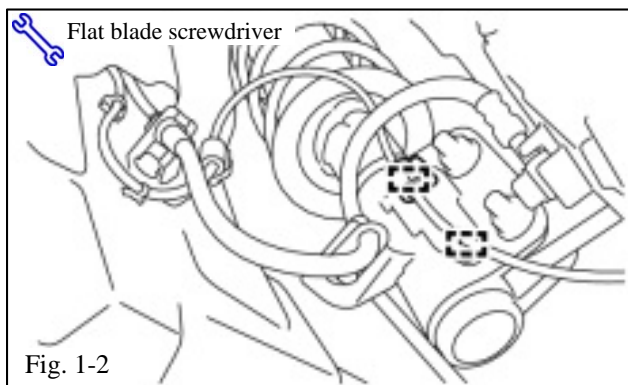
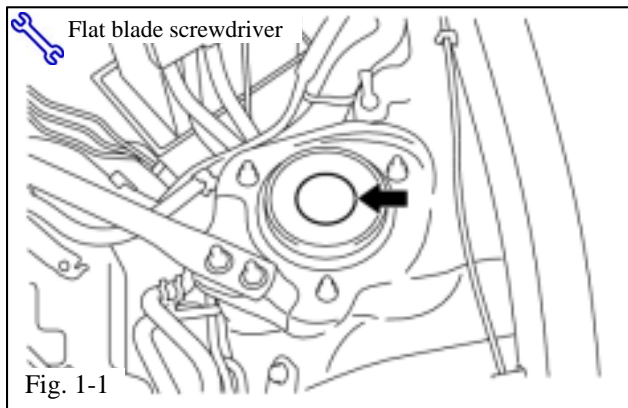

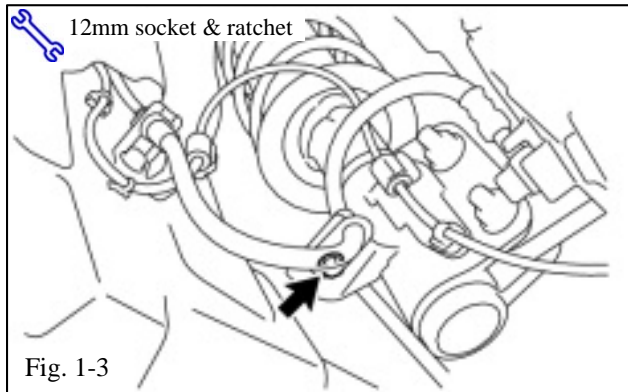

- (d) Use a 12mm socket to remove the bolt holding the brake hose to the shock absorber and retain it for installation (Fig. 1-3).
- (e) Separate the front flexible brake hose from the front shock absorber with coil spring.

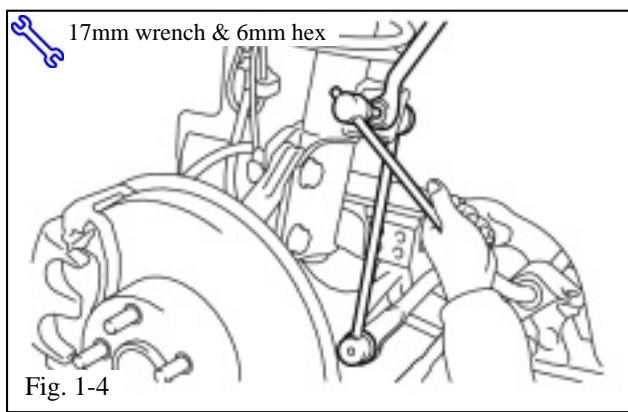

- (f) Use a 17mm wrench to remove the end link nut and discard it (Fig. 1-4).
- HINT:** If the ball joint turns together with the nut, use a 6mm hex wrench to hold the stud bolt.

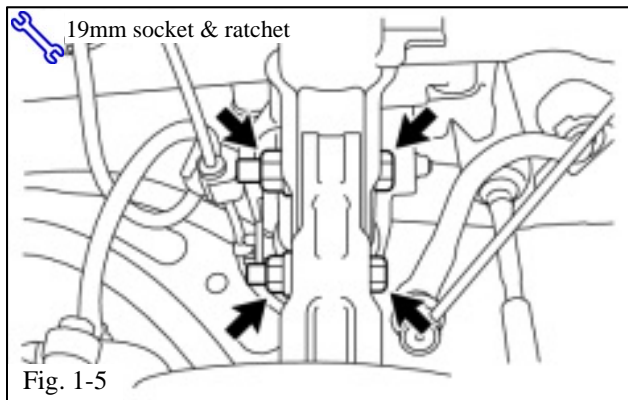

- (g) Separate the front stabilizer link assembly from the front shock absorber with coil spring.
- (h) Remove the front shock absorber with coil spring.
  - (1) Use a 19mm socket to remove the two bolts and two nuts (arrows, Fig. 1-5). Retain the two bolts for installation but discard the two nuts.
  - (2) Separate the front shock absorber with coil spring (lower side) from the steering knuckle.

**NOTE:** The bolts have different shaft diameters. The smaller shaft diameter goes on the bottom.

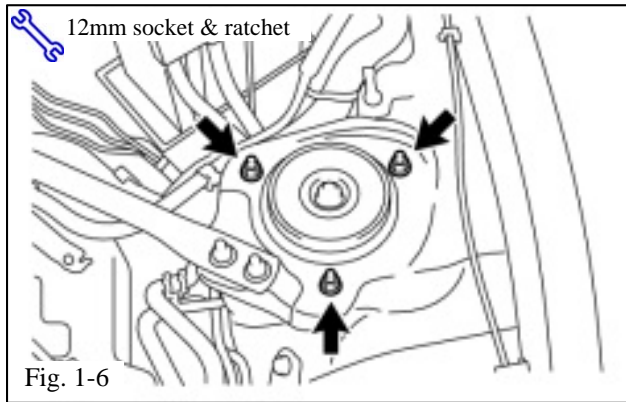

- (3) Use a 12mm socket to remove the three nuts from the front upper coil spring insulator and discard them (Fig. 1-6). They will not be reused.
- (4) Remove the front shock absorber with coil spring.

## 2. Disassemble the Front Shock Absorber and Spring Assembly.



- (a) Compress the shock and spring assembly (Fig. 2-1).

**HINT:** Support the assembly at the spring seat and compress the assembly at the sub-assembly support.

- (b) Confirm that the front coil spring becomes free and remove the lock nut.



- (1) Place SST 90729-97202 or a deep 17mm spark plug socket on the shock absorber lock nut (Fig. 2-2).

**+** **CAUTION:** Do not remove the lock nut if the front coil spring is not free of load.

- (2) Use a long socket 6mm hexagon wrench to hold the shock absorber rod and remove the lock nut with a 19mm ratcheting wrench (Fig. 2-2).

**!** **CAUTION:** Do not use an impact wrench. It may damage the internals of the shock absorber.

**!** **NOTE:** Be careful not to damage or deform the threads while removing the lock nut.

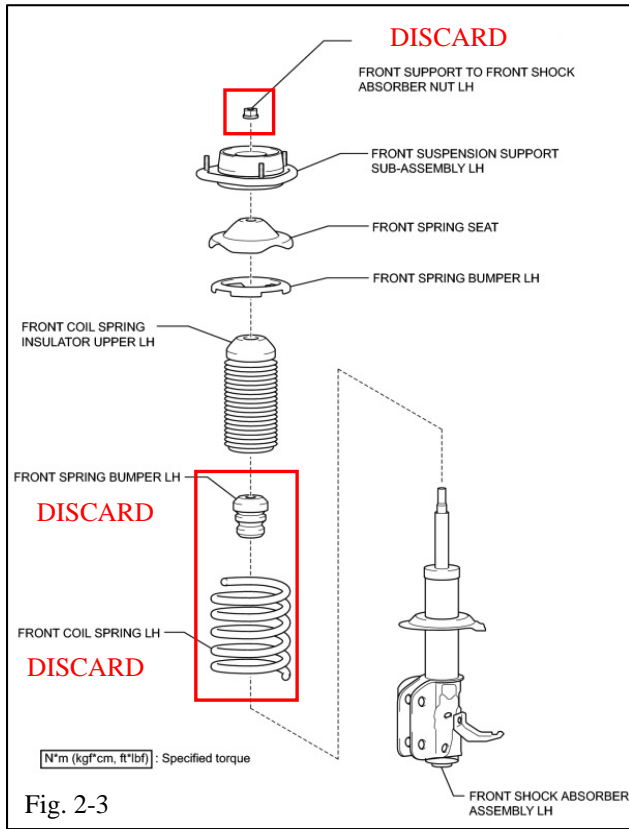

Fig. 2-3

(c) Remove and discard the coil spring, spring bumper, and lock nut (Fig. 2-3).

**3. Assemble the TRD Spring to the Front Shock Absorber.**

(a) Install the supplied front spring bumper to the front strut (Fig. 3-1).

**STOP NOTE:** The larger opening in the spring bumper faces downward.

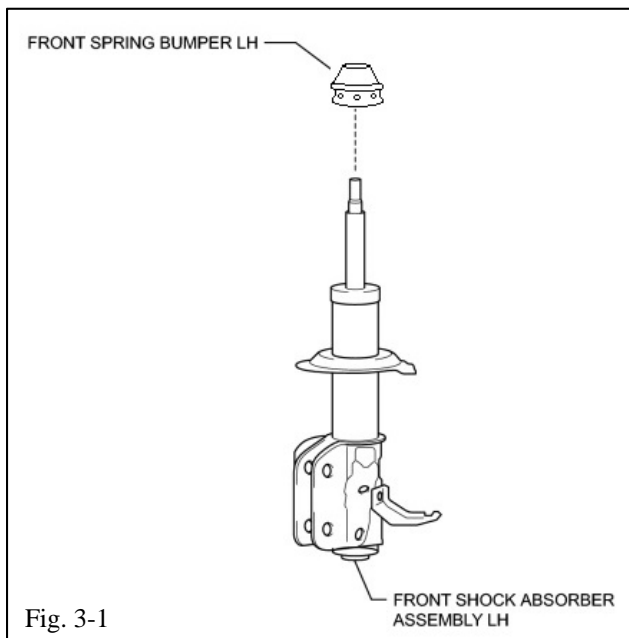

Fig. 3-1



(b) Place the shock on the spring compressor by supporting the shock on the spring seat.

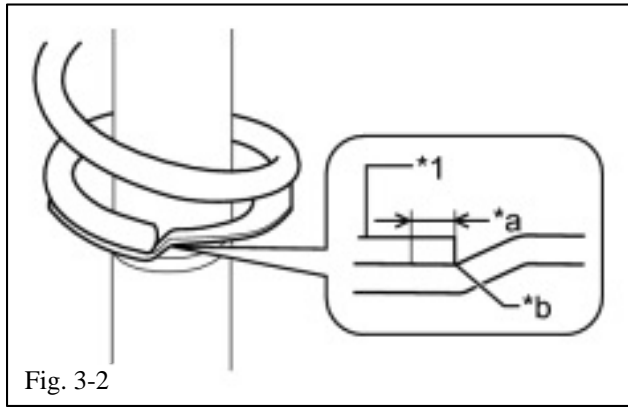

Fig. 3-2



Fig. 3-3

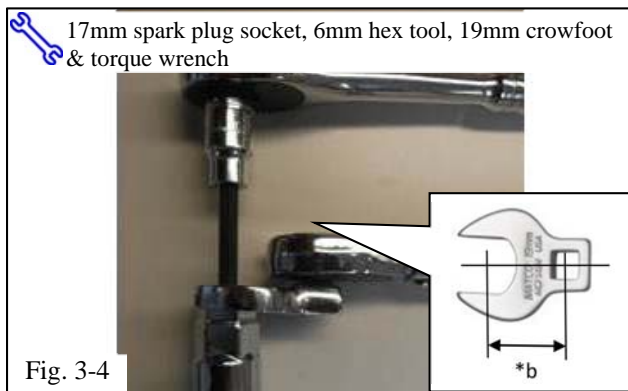

Fig. 3-4

(c) Assemble the TRD lowering spring to the shock absorber.

- (1) Index the TRD lowering spring onto the lower spring seat as shown in Fig. 3-2.
- (2) The end of the coil should be positioned 0 to 10 mm (\*a) from the spring seat stopper (\*b).

*1	Front coil spring
*a	0 to 10 mm (0 to 0.394 in.)
*b	Spring seat stopper

(d) Compress the shock absorber and TRD lowering spring assembly (Fig. 3-3).

**HINT:** Support the assembly at the spring the seat and compress the assembly at the subassembly support.

- (1) Install a new lock nut (SU003-02868) to the front shock absorber assembly.
- (2) Place SST 09729-97202 or a deep 17mm spark plug socket on the shock absorber lock nut.
- (3) Use a long socket 6mm hexagon wrench to hold the shock absorber rod and torque the lock nut per below directions using a 19mm crowfoot (Fig. 3-4).

**S** Torque, with crowfoot: 50 N-m (37 ft-lbf)

Torque, without crowfoot: 55 N-m (41 ft-lbf)

	Torque wrench length = 300 mm
*b	30 mm (1.181 in.)

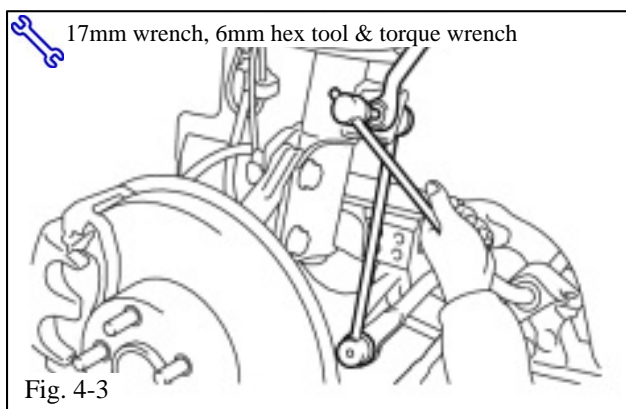
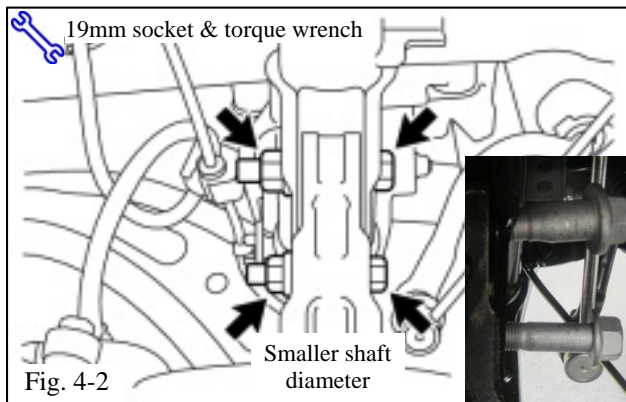
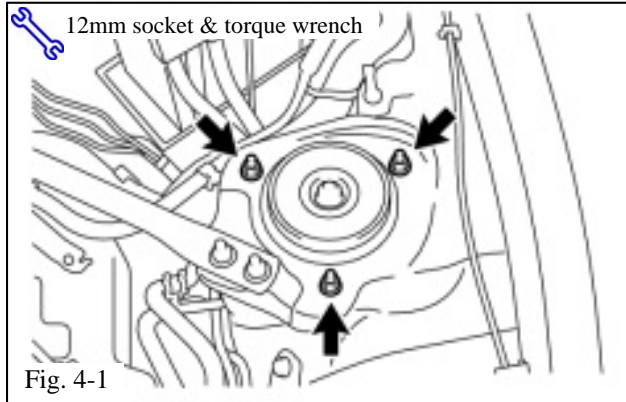

**4. Install the Front Shock Absorber Assembly.**

(a) Install the upper side of the shock assembly.

- (1) Use three new supplied nuts (SU003-04500) and a 12mm socket to install the front shock absorber with TRD lowering spring (upper side) (Fig. 4-1).

**⚠ Torque: 23 N-m (17 ft-lbf)**

(b) Install the lower side of the strut assembly.

- (1) Install the front shock absorber with TRD lowering spring (lower side) to the steering knuckle and insert the two bolts (Fig. 4-2).

**NOTE:** Insert the bolts from the rear of the vehicle. The bolt with the smaller shaft diameter goes on the bottom.

- (2) Use a 19mm socket to install the two supplied nuts (SU003-02889).

**⚠ Torque: 155 N-m (114 ft-lbf)**

**HINT:** Use a 19mm wrench to keep the bolts from rotating when tightening the nuts.

(c) Install the front stabilizer link assembly to the front shock absorber assembly.

- (1) Use a 17mm wrench to install the supplied end link nut (SU003-04506) (Fig. 4-3).

**⚠ Torque: 46 N-m (34 ft-lbf)**

**HINT:** If the ball joint turns together with the nut, use a 6mm hex wrench to hold the stud bolt.

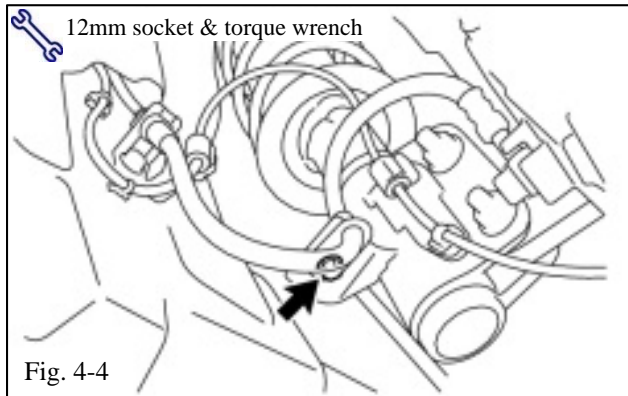

(d) Use a 12mm socket to install the front flexible hose to the front shock absorber assembly with the bolt (Fig. 4-4).

**S** Torque: 33 N-m (24 ft-lbf)

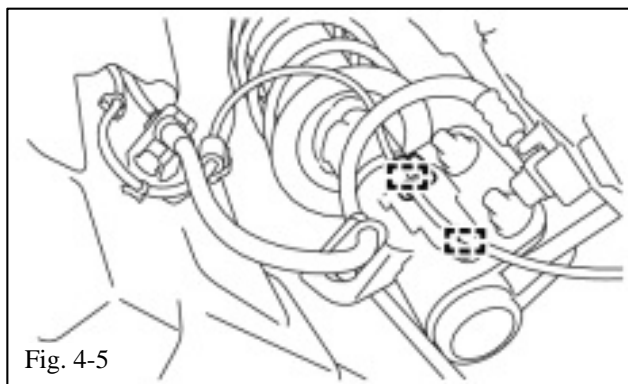

(e) Install the front speed sensor to the front shock absorber assembly with the two clamps (Fig. 4-5).

**NOTICE:** Do not twist the front speed sensor during installation.

(f) Replace the front suspension support dust cover.

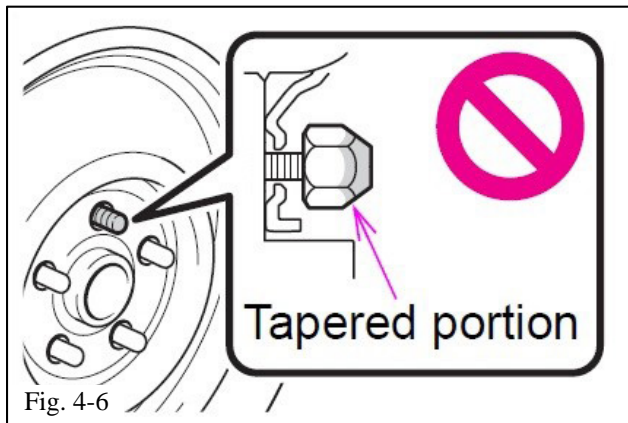

(g) Install the front wheels (Fig. 4-6).

**S** Torque: 120 N-m (89 ft-lbf)

**STOP** NOTE: Perform two cycles of torquing.



**5. Remove the Rear Shock Absorber and Spring Assembly.**

- (a) Remove the rear wheels.
- (b) Disconnect the lower end of the shock absorber assembly from the lower control arm.

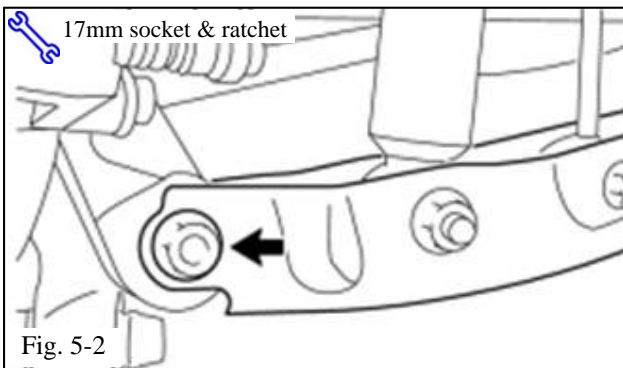
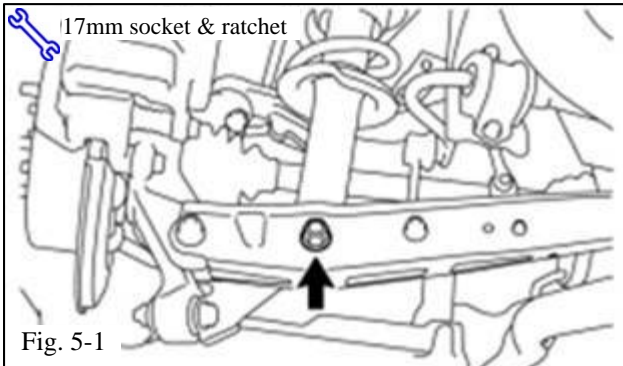

- (1) Use a 17 mm socket to remove the lower nut and bolt from the shock assembly (Fig. 5-1). Retain the bolt for installation but discard the nut.

- (2) Use a 17mm socket to remove the outer nut and bolt from the lower control arm assembly (Fig. 5-2). Retain the bolt for installation but discard the nut.

**HINT:** It is easier to pull down on the lower control arm assemblies when both the LH and RH lower control arms are free.

- (3) Pull down on the lower control arm assembly to pull the lower control arm away from the lower end of the shock absorber.

- (c) Disconnect the upper side of the shock absorber assembly from the vehicle.

- (1) Remove the luggage compartment floor mat (Fig. 5-3).
- (2) Lift the front and lower edge of the luggage compartment trim cover to gain access to the top of the shock assembly nuts.

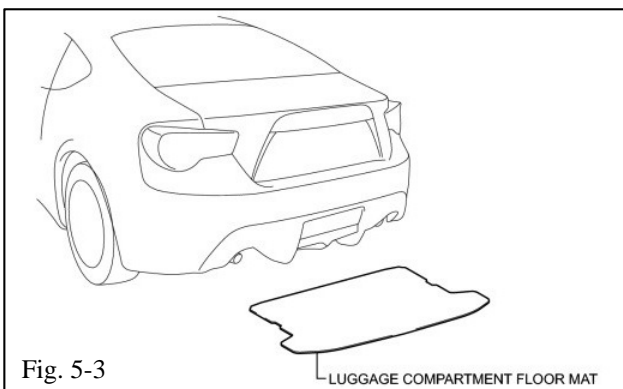

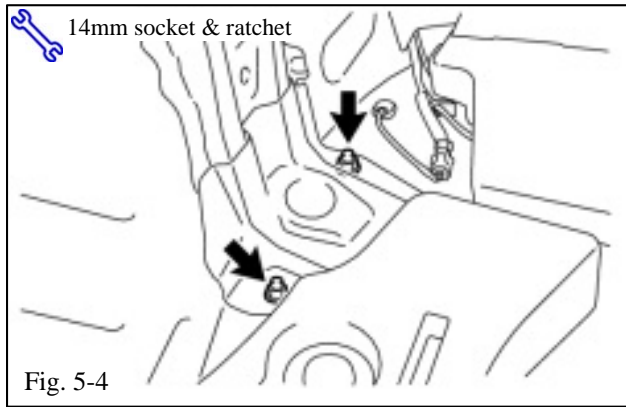

(3) Use a 14mm socket to remove the two nuts from the upper shock mount and discard them (Fig. 5-4).

**⚠ CAUTION:** The installer may need assistance to hold the rear shock assembly to prevent it from falling accidentally.

(4) Remove the shock absorber and spring assembly.

## 6. Disassemble the Rear Shock Absorber and Spring Assembly.



(a) Compress the shock absorber and spring assembly as shown in Fig. 6-1.

**HINT:** Support the assembly at the spring seat and compress the assembly at the subassembly support.

(b) Confirm the rear coil spring becomes free and remove the lock nut.

(1) Place SST 09729-18010 or a deep 14mm spark plug socket on the shock absorber lock nut (Fig. 6-1).

**+ CAUTION:** Do not remove the lock nut if the rear coil spring is not free of load.

(2) Use a long socket 5mm hexagon wrench to hold the shock absorber rod and remove the lock nut with a 17mm ratcheting wrench (Fig. 6-2).



**⚠ CAUTION:** Do not use an impact wrench. It may damage the internals of the shock absorber.

**⚠ NOTE:** Be careful not to damage or deform the threads while removing the lock nut.

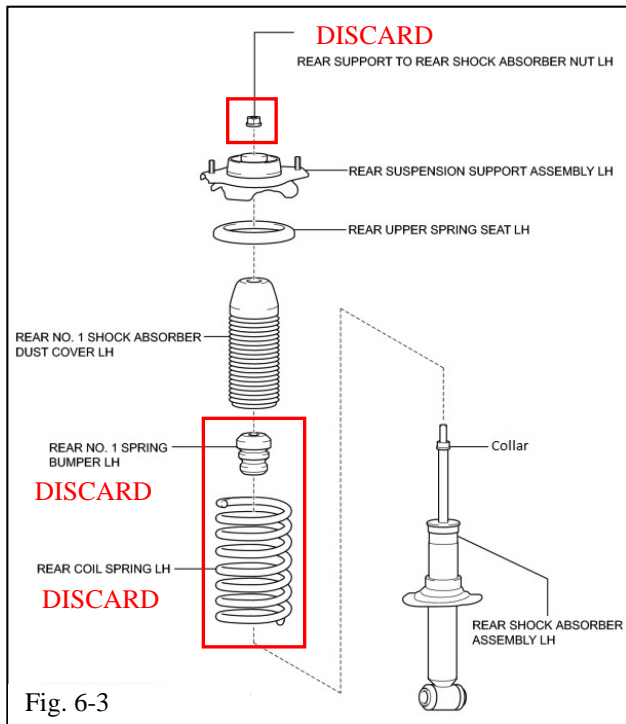

(c) Remove and discard the rear coil spring, spring bumper and lock nut (Fig. 6-3).

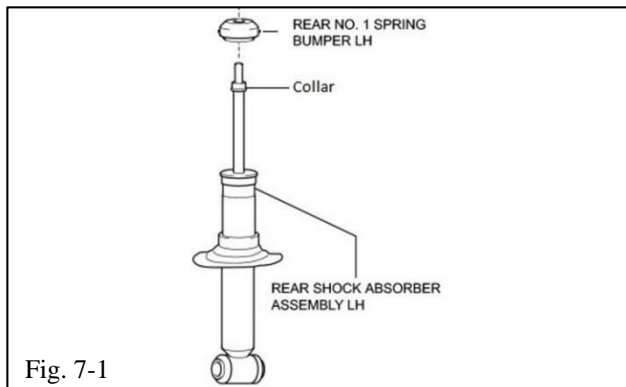

**7. Assemble the TRD Spring to the Rear Shock Absorber.**

- (a) Install the new TRD rear spring bumper onto the rear shock shaft (Fig. 7-1).
  - (1) Confirm the collar at the top of the shock rod is in place.
  - (2) The smaller hole on the spring bumper will face upward.
  - (3) Install the dust cover.
- (b) Place the rear shock absorber on the spring compressor by supporting the shock absorber on the spring seat.



Fig. 7-2

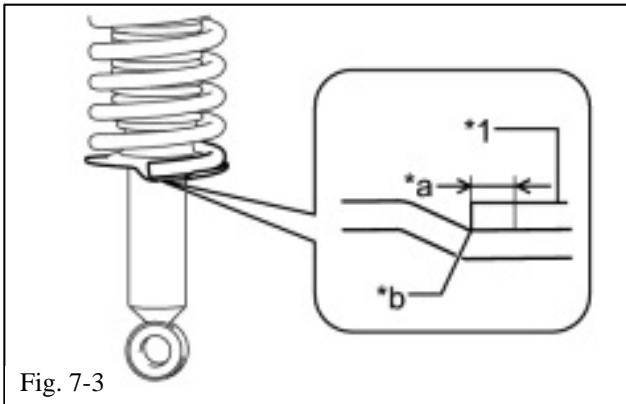

Fig. 7-3

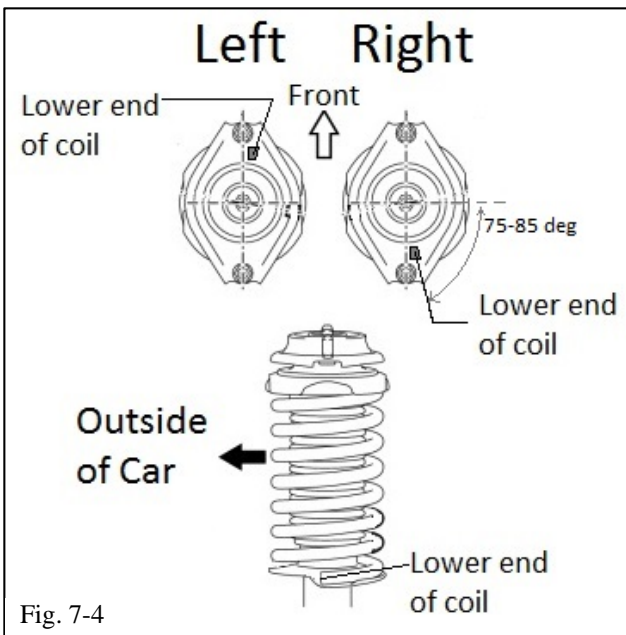

Fig. 7-4

(c) Assemble the TRD lowering spring to the shock absorber.

- (1) Clearly identify the top and bottom of the spring (Fig. 7-2).
  - a. The tight wound coils face upward.
  - b. The TRD lettering will face right side up.
  - c. The top coil end is closed.
  - d. The bottom coil end is open roughly 12mm.

(2) Index the TRD lowering spring onto the lower spring seat as shown in Fig. 7-3. The end of the coil should be positioned 0 to 10 mm (\*a) from the spring seat stopper (\*b).

*1	Rear coil spring
*a	0 to 10 mm (0 to 0.394 in.)
*b	Spring seat stopper

(3) Install the rear support assemblies as shown in Fig. 7-4. Adjust the rear suspension support assembly to the installation position of the shock absorber so that the studs are positioned as shown in the illustration

**NOTE:** Make sure that the left lower coil spring end faces toward the front of the vehicle and the right lower spring end faces toward the rear.



(d) Compress the shock absorber and TRD lowering spring assembly (Fig. 7-5).

**HINT:** Support the assembly at the spring seat and compress the assembly at the subassembly support.

(1) Install a new lock nut (SU003-02869) to the rear shock absorber assembly and place SST 09729-18010 or a deep 14 mm spark plug socket on the shock absorber lock nut (Fig. 7-5).

(2) Use a long socket 5mm hexagon wrench to hold the shock absorber rod and torque the lock nut per below directions using a 17 mm crowfoot (Fig. 7-6).

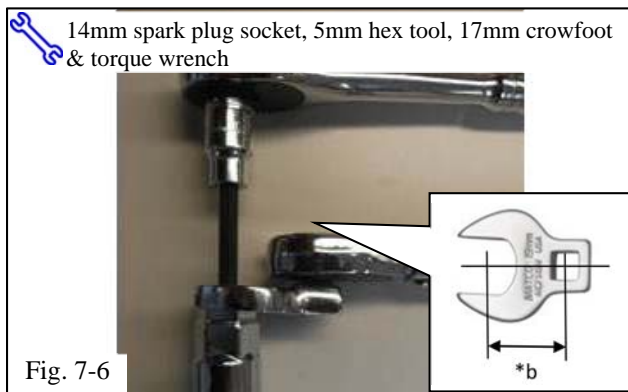

**⚠ Torque, with crowfoot: 23 N-m (18 ft-lbf)**

**Torque, without crowfoot: 25 N-m (17 ft-lbf)**

	Torque wrench length = 300 mm
*b	30 mm (1.181 in.)

## 8. Install the Rear Shock Absorber Assembly.

(a) Install the upper side of the rear shock absorber assembly.

(1) Install the shock absorber assembly with the TRD lowering spring to the vehicle using the two supplied nuts (SU003-02869) and temporarily tighten (Fig. 8-1).

**CAUTION:** The installer may need assistance to hold the rear shock assembly to prevent it from falling accidentally.

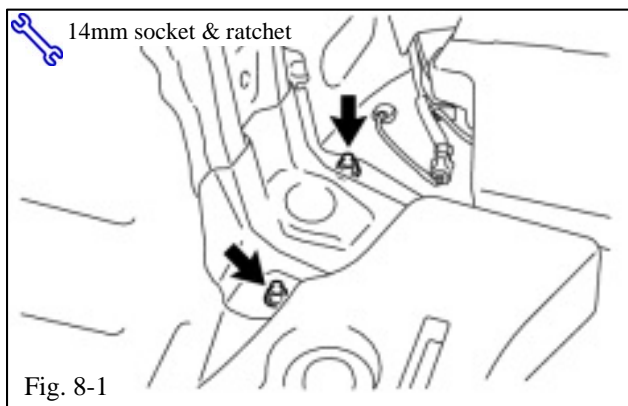

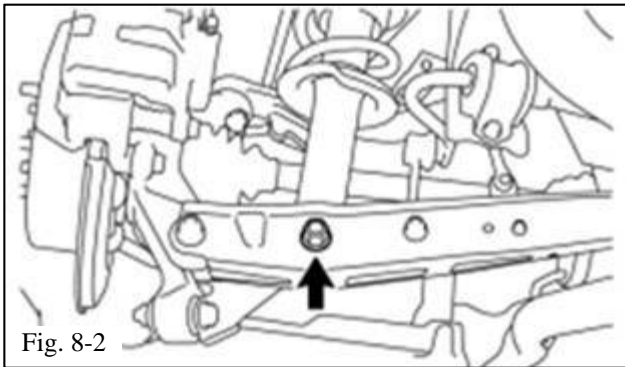

- (2) Confirm the lower shock eye is in the correct location and install the lower shock bolt (Fig. 8-2).

**HINT:** The bolt may be inserted from either direction.

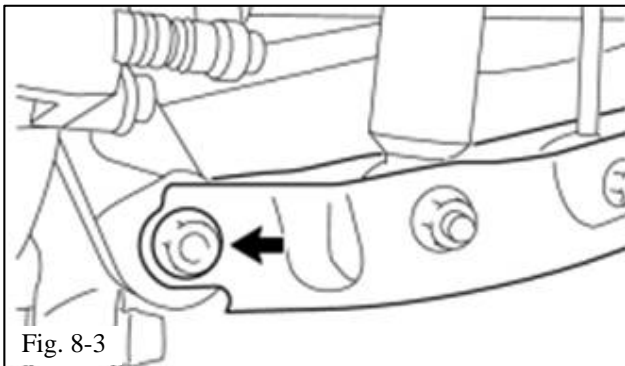

- (3) Insert the lower control arm bolt from the front of the vehicle (Fig. 8-3).

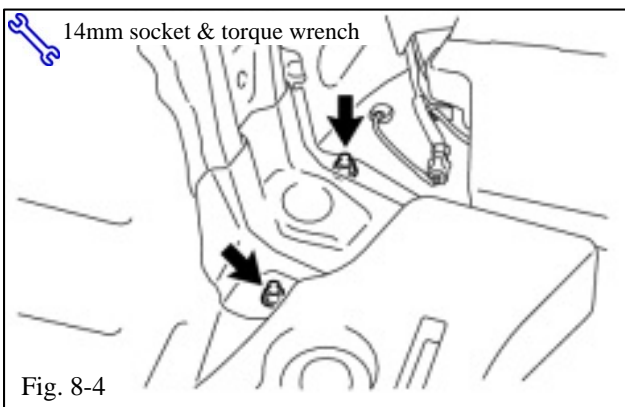

- (4) Use a 14mm socket to install the two supplied nuts (SU003-02869) on the upper shock absorber assembly (Fig. 8-4).

**Torque: 30 N-m (22 ft-lbf)**

- (b) Install the lower side of the shock assembly.

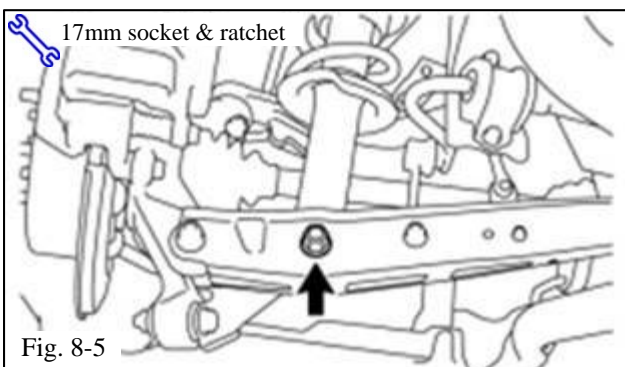

- (1) Use a 17mm socket to install the supplied nut (SU003-02870) on the lower shock assembly (Fig. 8-5).

**NOTE:** Do not torque the nut during this step.

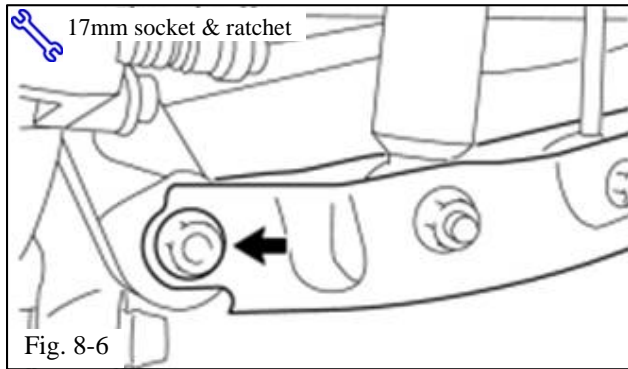

(2) Use a 17mm socket to install the supplied nut (SU003-02870) on the lower control arm (Fig. 8-6).

**NOTE:** Do not torque the nut during this step.

(c) Place the suspension at normal ride height.

(1) Support the axle carrier (i.e. transmission jack) with a wooden block placed between the jack and axle carrier.

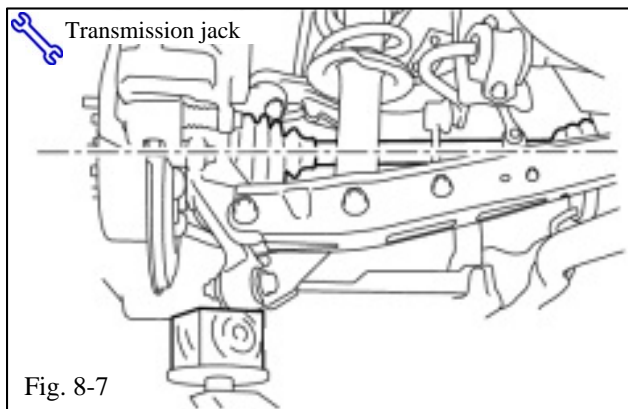

(2) Apply a load to the suspension so that the rear drive shaft assembly becomes level (Fig. 8-7).

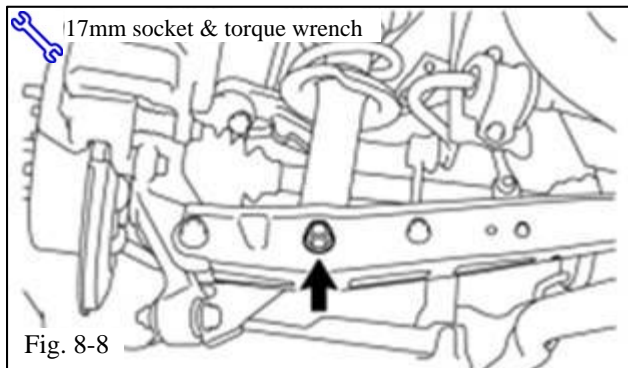

(d) Use a 17 mm socket to torque the lower shock assembly nut (Fig. 8-8).

**⚠ Torque: 80 N-m (59 ft-lbf)**

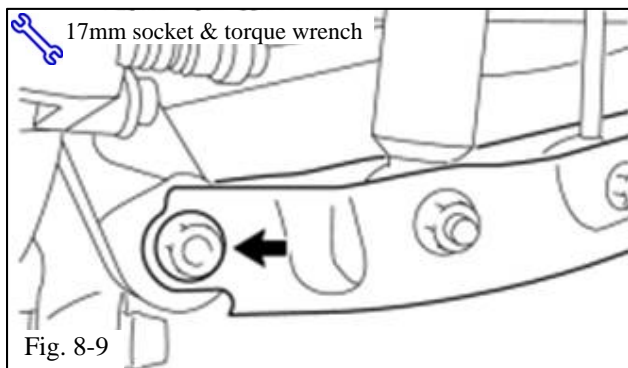

(e) Use a 17 mm socket to torque the lower control arm nut (Fig. 8-9).

**⚠ Torque: 80 N-m (59 ft-lbf)**

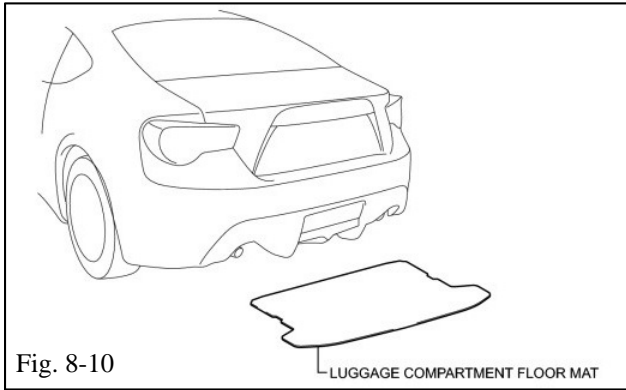

- (f) Install the luggage compartment floor mat (Fig. 8-10).

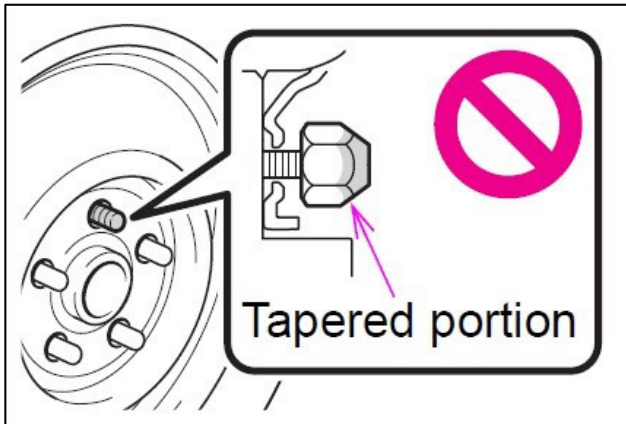

- (g) Install the rear wheels (Fig. 8-11).

**S** Torque: 120 N-m (89 ft-lbf)

**STOP** NOTE: Perform two cycles of torquing.

### 9. Inspect and Adjust the Wheel Alignment.

- (a) Adjust the rear toe settings (if necessary).

- (1) Loosen the tie rod adjusting cam set nut (19mm, Fig. 9-1).
- (2) Adjust the rear toe cams so that there is a total toe of +2mm (+3/-2mm) (22mm, Fig. 9-1).

**NOTE:** The rear camber may be greater than 2 degrees. This is a normal condition for this vehicle.

- (3) Tighten the toe adjust cam nut.

**S** Torque: 100 N-m (74 ft-lbf)

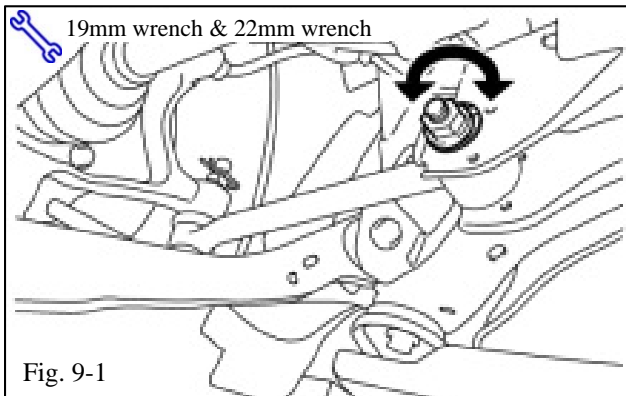



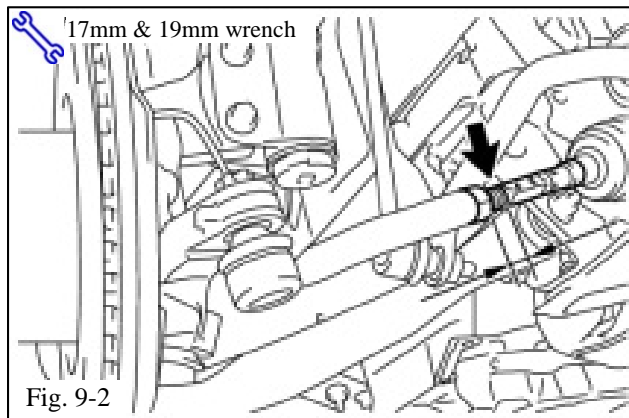

(b) Adjust the front toe settings.



- (1) Loosen the front tie rod end locking nuts (Fig. 9-2).
- (2) With the steering wheel held in the center position adjust tie rod ends so that total toe is set at  $0\text{mm} \pm 3\text{mm}$ .
- (3) Tighten the front tie rod end locking nuts (Fig. 9-2).

**S** Torque: 74 N-m (55 ft-lbf)

**HINT:** Temporarily tighten the lock nut while holding the hexagonal part of the steering rack end so that the lock nut and the steering rack end do not turn together. Hold the flat of the tie rod end and tighten lock nut.

## 10. Perform VSC Sensor Neutral Memorization.

### NOTE:

-  • While obtaining the zero point, keep the vehicle stationary and do not vibrate, tilt, move, or shake it. (Do not start the engine.)
-  • Be sure to perform this procedure on a level surface (with an inclination of **less than 1 degree**). **DO NOT PERFORM THIS PROCEDURE UNLESS YOU CAN CONFIRM YOU ARE ON A LEVEL SURFACE LIKE A CALIBRATED ALIGNMENT LIFT.**



**HINT:** When VSC sensor neutral memorization is performed, the yaw rate and acceleration sensor and the steering sensor zero point calibration are performed at the same time.

- (a) Turn the ignition switch off.
- (b) Check that the steering wheel is centered.
- (c) Check that the shift lever is in neutral.
- (d) Apply the parking brake by pulling up the parking brake lever.
- (e) Connect the Techstream to the DLC3.
- (f) Turn the ignition switch on.
- (g) Turn the Techstream on.
- (h) Enter the following menus: Chassis / ABS/VSC/TRAC / Utility / VSC Sensor Neutral Memorization.
- (i) According to the display on the Techstream, perform VSC sensor neutral memorization.
- (j) Turn the ignition switch off and disconnect the Techstream.

Checklist - these points **MUST** be checked to ensure a quality installation.

Check:	Look For:
<p><u>Accessory Function Checks</u></p> <p><input type="checkbox"/></p> <p><input type="checkbox"/></p> <p><input type="checkbox"/></p> <p><input type="checkbox"/></p>	
<p><u>Vehicle Function Checks</u></p> <p><input type="checkbox"/> Confirm VSC and ABS do not have fault codes</p> <p><input type="checkbox"/></p> <p><input type="checkbox"/></p>	<p>The VSC and ABS warning lights should turn off once the vehicle is started.</p>
<p><u>Vehicle Appearance Check</u></p> <p><input type="checkbox"/> After accessory installation and removal of protective cover(s), perform a visual inspection.</p>	<p>Ensure no damage (including scuffs and scratches) was caused during the installation process. (For PPO installations, refer to TMS Accessory Quality Shipping Standard.)</p>